

**100%** Money Back  
**Guarantee**

**Vendor:**HP

**Exam Code:**HPE6-A45

**Exam Name:**Implementing Aruba Campus Switching solutions

**Version:**Demo

### QUESTION 1

Refer to the exhibit.

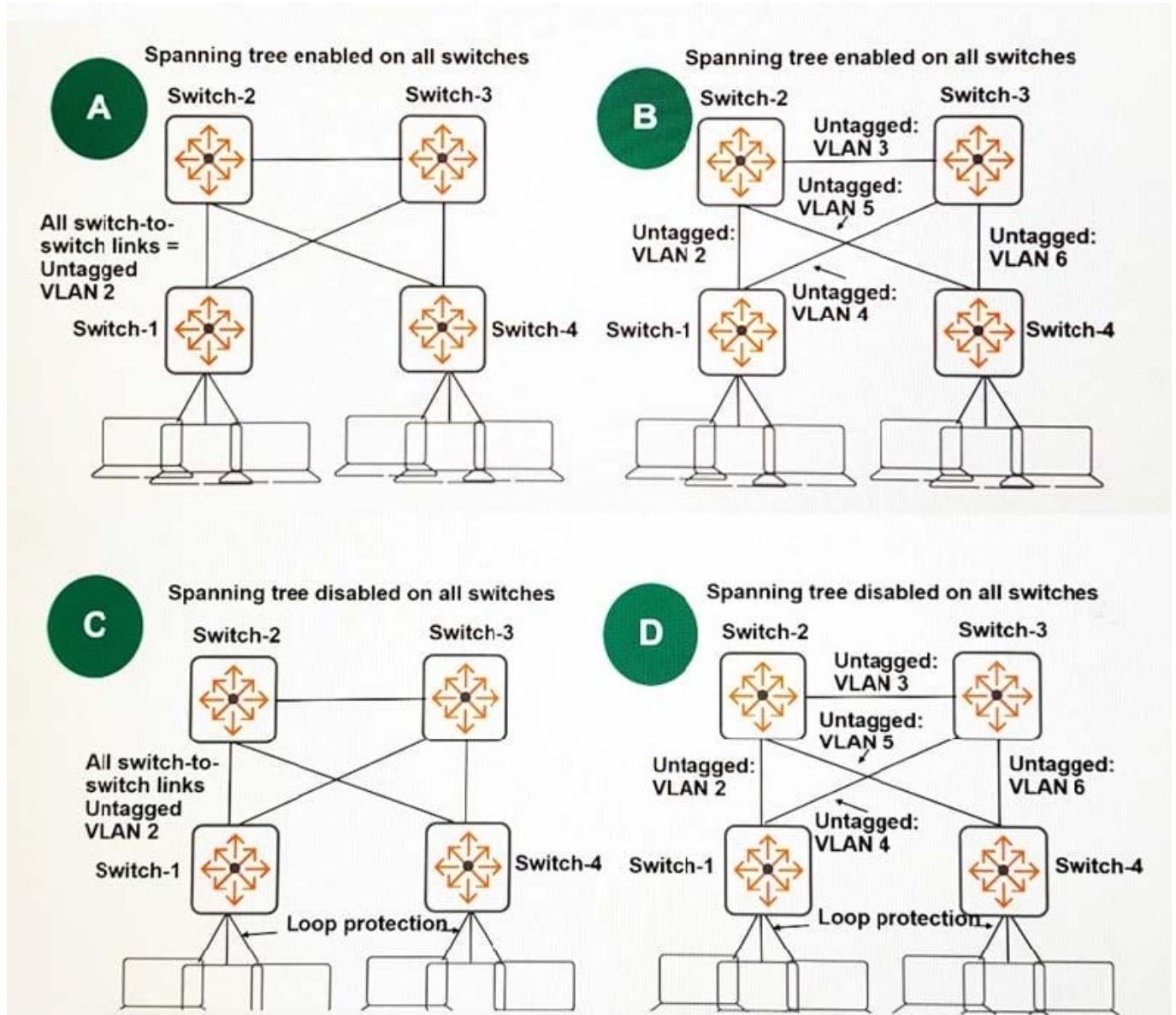

Every switch in the exhibit will route traffic. The company requires a topology in which failover for switch-to-switch links is exclusively handled by the routing protocol and occurs as quickly as possible.

Which topology should the administrator use?

- A. A
- B. B
- C. C

D. D

Correct Answer: B

---

## QUESTION 2

A customer wants access layer switches that support routing, ACLs, VSF stacking, and SFP+.

Which Aruba switch model meets the customer's requirements?

- A. 2530
- B. 2930F
- C. 3810
- D. 8400

Correct Answer: B

---

## QUESTION 3

What is one difference between BPDU protection and root guard?

- A. BPDU protection works with RPVST+, RSTP, and MSTP. Root guard works with RSTP or MSTP, but not RPVST+.
- B. BPDU protection blocks a port if it receives any BPDU, but root guard blocks a port only if the BPDU indicates a better root path.
- C. BPDU protection is typically implemented on edge ports, but root guard is typically implemented on uplinks with the root port role.
- D. BPDU protection drops BPDUs received on a port, but does not block the port. Root guard blocks the port if it receives a BPDU.

Correct Answer: B

Reference: <http://ericleahy.com/index.php/bpdu-guard-bpdu-filter-root-guard-loop-guard-udld/>

---

## QUESTION 4

OSPF Area 1 has two ABRs. One ABR is configured with this range for Area 1: 10.10.0.0/16. The other ABR is not configured with a range for Area 1.

Which type of issue occurs due to this mismatch?

- A. The ABRs create a discontinuous area and disrupt intra-area routing between devices within Area 1.

- B. The ABR core would send Area 1 traffic destined to the other switch through an access switch.
- C. The ABRs lose adjacency entirely and cannot route traffic between each other at all.
- D. The ABRs lose adjacency in Area 1 and must route all traffic to each other through Area 0.

Correct Answer: A

---

#### QUESTION 5

A network administrator needs to create a QoS policy on an AOS-Switch. What is one component that the administrator must create before the policy?

- A. an extended IPv4 ACL
- B. a traffic behavior
- C. an extended MAC ACL
- D. a traffic class

Correct Answer: D

---

#### QUESTION 6

A company requires AOS-Switches at the campus core. The switches: Will act as the default gateways for several campus VLANs Must provide redundancy for their services and tolerate the loss of a link or an entire switch Must recover from the failure of one of the switches within a second or less

VRRP and MSTP are proposed to meet these requirements. What is an issue with this proposal?

- A. VRRP provides redundancy against lost links but not a failed switch
- B. VRRP provides routing redundancy but not default gateway redundancy
- C. VRRP does not interoperate with MSTP
- D. VRRP takes longer than a second to fail over

Correct Answer: D

---

#### QUESTION 7

Refer to the exhibit.

```

Switch# ping 10.1.10.5
10.1.10.5 is alive, time = 3 ms

Switch# show radius authentication
Status and Counters - RADIUS Authentication Information
  NAS Identifier           : Access-1
  Invalid Server Addresses : 0

Server IP Addr      UDP
                   Port   Timeouts  Requests  Challenges  Accepts  Rejects
-----
10.1.10.5          1812    6         3         0           0        0

```

A network administrator sets up 802.1X authentication to a RADIUS server on an AOS-Switch. The RADIUS server and user devices are both set up to use PEAP MSCHAPv2. The administrator tests the authentication and sees the output shown in the exhibit.

Which issue could cause this output?

- A. The administrator entered the wrong password for the test account
- B. The RADIUS shared secret does not match on the switch and the server
- C. The switch does not have a certificate for port-access installed on the switch
- D. The switch port is set for user mode 802.1X, but the RADIUS server is set for port mode

Correct Answer: B

---

### QUESTION 8

What is the minimum requirement for a device to pass local MAC authentication (LMA) on an AOS-Switch?

- A. The device MAC address matches a default MAC group, which is enabled but not necessarily associated with a profile.
- B. The device MAC address matches a MAC group, address, OUI, or range that is associated with an LMA profile.
- C. The device MAC address matches a default MAC group that is associated with an LMA profile.
- D. The device MAC address matches a configured MAC group, address, OUI, or range, which is not necessarily associated with a profile.

Correct Answer: B

---

### QUESTION 9

Refer to the exhibits. Exhibit 1

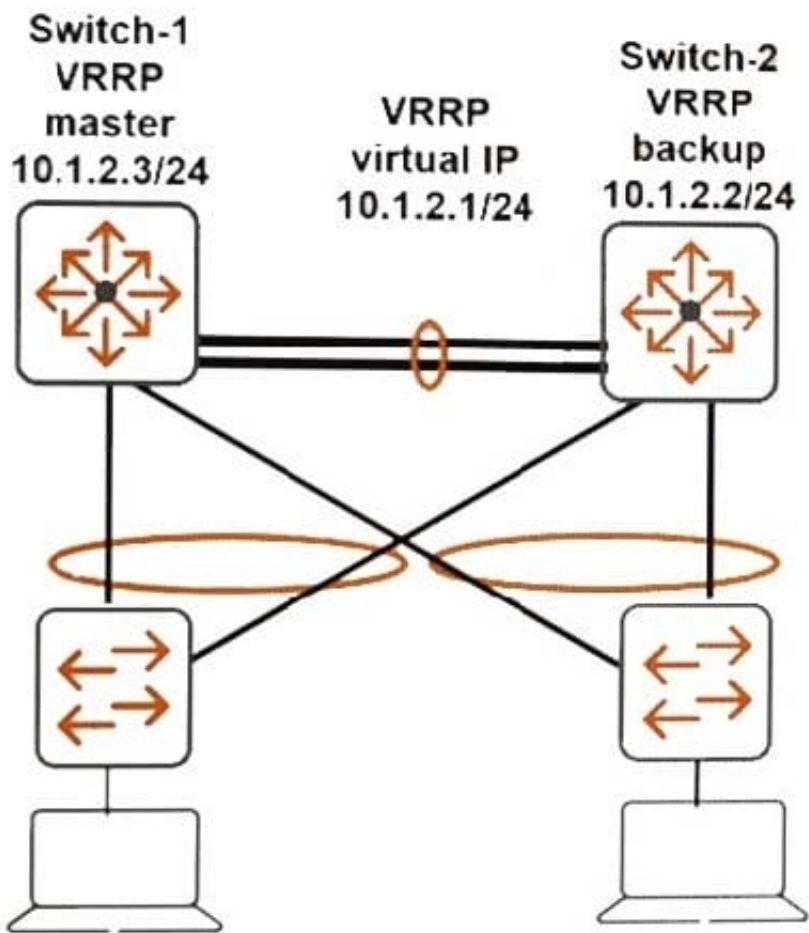

Exhibit 2

VRRP Enabled : Yes  
Traps Enabled : Yes  
Virtual Routers Respond To Ping Requests : No  
VRRP Nonstop Enabled : No

VRRP Global Router Configuration Information  
VLAN ID : 2  
Virtual Router ID : 2

Administrative Status [Disabled] : Enabled  
Mode [Uninitialized] : Backup  
Priority [100] : 254  
Advertisement Interval [1] : 1  
Preempt Mode [True] : True  
Preempt Delay Time [0] : 120  
Respond To Virtual IP Ping Requests [Yes] : No  
Version [2] : 2  
Null authentication compatibility [False] : False  
Primary IP Address : Lowest

IP Address

-----  
10.1.2.1

Switch-1 and Switch-2 are configured to provide VRRP in VLAN 2. The default gateway for VLAN 2 is set to the VRRP virtual IP. Client-1 in VLAN 2 cannot ping its default gateway.

Based on the exhibits, what can administrators determine?

- A. The VRRP preempt delay time has not yet expired, and administrators should try to ping the gateway again in several minutes.
- B. Switch-1 and Switch-2 have the same virtual router ID. The conflict interferes with connectivity.
- C. Preempt mode is enabled on both Switch-1 and Switch-2, so the Master role continues to alternate between them, and the pings go astray.
- D. This is the expected behavior, and Switch-1 should still be able to route traffic for Client-1.

Correct Answer: A

---

## QUESTION 10

Refer to the exhibits.

Exhibit 1

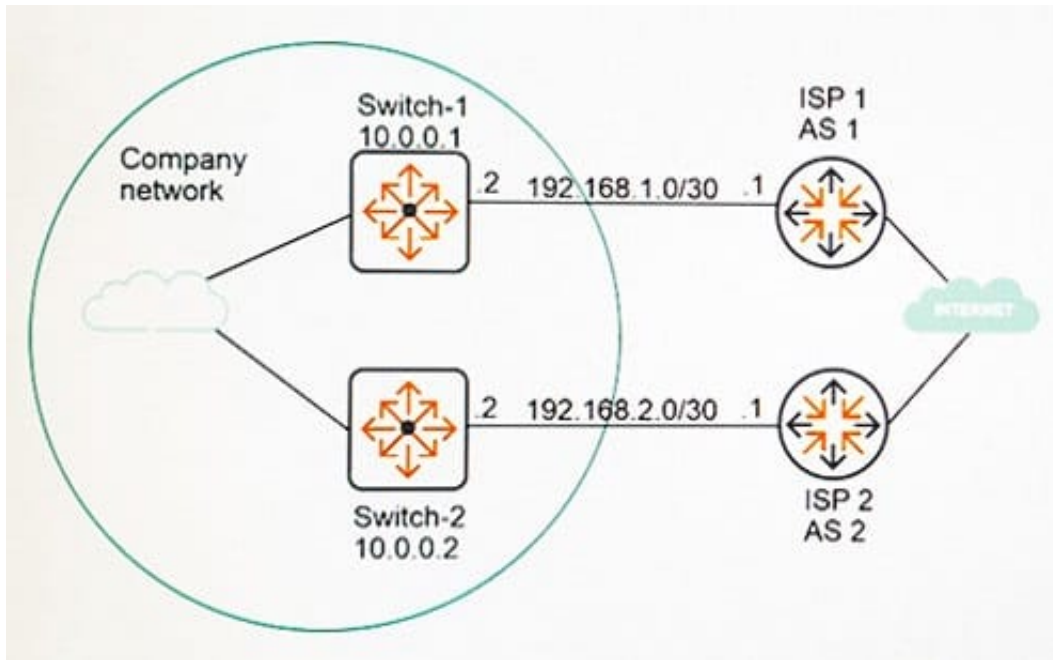

Exhibit 2



Former state

```
Switch-1# show ip bgp
Local AS: 46500 Local Router-id : 10.0.0.1
BGP Table Version : 30
Status codes: * - valid, > - best, i - internal, e - external,
s- stale
Origin codes: i - IGR, e - EGR, ? - incomplete
Network          Nexthop          Metric    LocalPref    Weight    AsPath
-----
*> 198.51.100.0/24          0          32768        i
* i 198.51.100.0/24 10.0.0.2      0          100          0          i
* i 192.0.2.0/24 192.168.2.1  0          100          0          2 3 i
*>e 192.0.2.0/24 192.168.1.1  0          0            1 3 i
*>i 203.0.113.0/24 192.168.2.1  0          100          0          2 i
* e 203.0.113.0/24 192.168.1.1  0          0            1 2 i
```

Current state

```
Switch-1 (config)# show ip bgp
Local AS: 46500 Local Router-id : 10.0.0.1
BGP Table Version : 30
Status codes: * - valid, > - best, i - internal, e - external,
s- stale
Origin codes: i - IGR, e - EGR, ? - incomplete
Network          Nexthop          Metric    LocalPref    Weight    AsPath
-----
*> 198.51.100.0/24          0          32768        i
* i 198.51.100.0/24 10.0.0.2      0          100          0          i
*>i 192.0.2.0/24 192.168.2.1  0          100          0          2 3 i
* e 192.0.2.0/24 192.168.1.1  0          0            1 4 3 i
*>i 203.0.113.0/24 192.168.2.1  0          100          0          2 i
* e 203.0.113.0/24 192.168.1.1  0          0            1 2 i
```

Exhibit 1 shows a portion of the BGP routing table when the BGP solution was first deployed. Exhibit 2

shows the same portion at the current time. What can explain the current state?

- A. Due to changes in the private network, Switch-1 can no longer reach 192.168.2.1.
- B. Switch-1 can no longer reach ISP 1 at 192.168.1.1.
- C. Due to changes at ISP 1, Switch-1 now selects a different best route.
- D. An administrator has applied a route map on Switch-1 that filters advertised routes.

Correct Answer: C

---

## QUESTION 11

Refer to the exhibit.

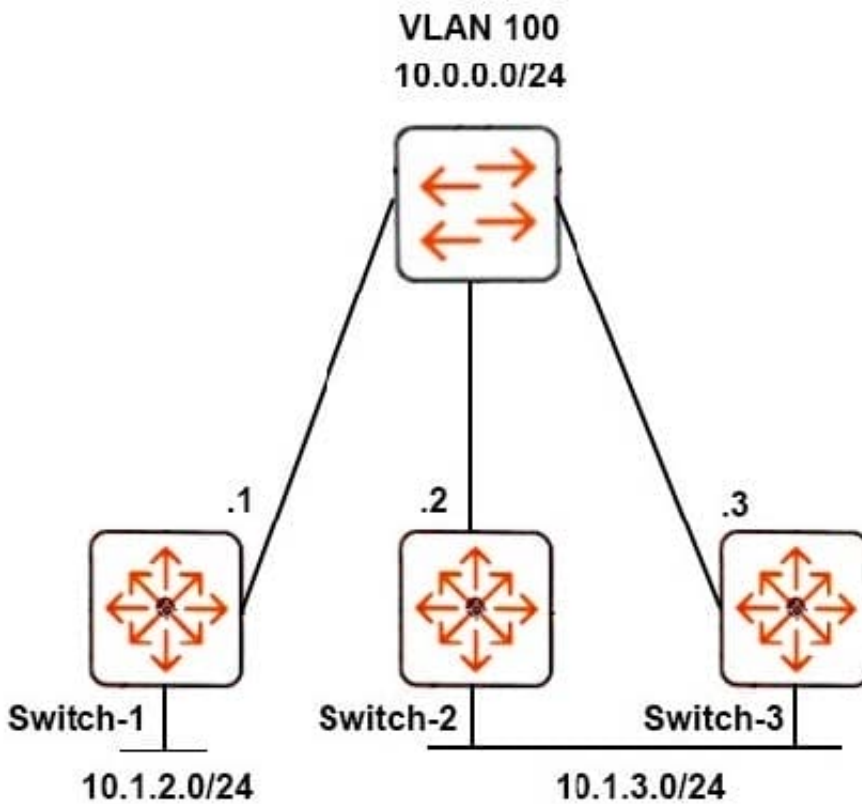

The network administrator wants to reduce failover time if a switch link in VLAN 100 goes down.

What should the administrator do?

- A. Configure echo mode BFD on VLAN 100 on all OSPF routing devices on VLAN 100.
- B. Lower the dead timer on the BDR of VLAN 100.
- C. Lower the hello timer only on the BDR of VLAN 100.
- D. Configure graceful restart on all of the OSPF routing devices on VLAN 100.

Correct Answer: A

---

## QUESTION 12

Refer to the exhibits. Exhibit 1

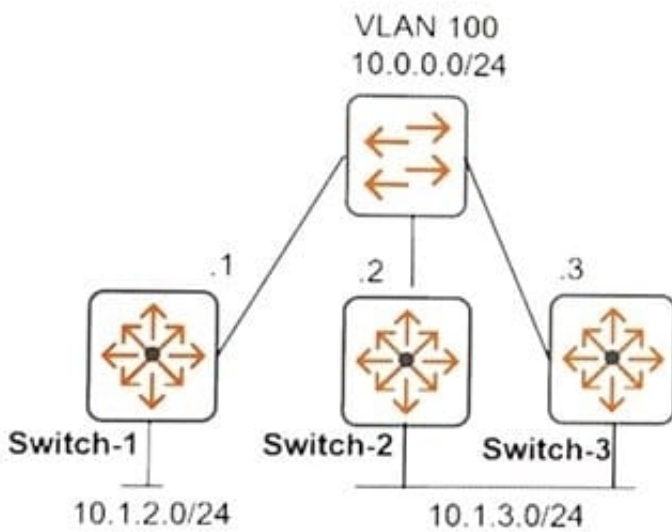

Exhibit 2

```
Switch-2# show log -r
E 09/02/17 04:50:23 02703 OSPF: AM1: ADJCHG: Neighbor with Router ID 10.0.0.1
    on vlan-100 moved to Down state - adjacency lost.
W 09/02/17 04:50:23 05076 bfd: AM1: BFD session 1 error NeighborSessionDown.
I 09/02/17 04:50:23 05080 bfd: AM1: Session 1 under OSPF changed to DOWN.
```

Exhibit 1 shows the topology for the network. The network administrator sees the log entries shown in Exhibit 2. Which type of failure is indicated?

- A. A link between Switch-1 and Switch-2 went down. BFD detected the lost connectivity and behaved as expected.
- B. Graceful restart helper was not enabled on Switch-2, so BFD was unable to operate correctly, and the session was taken down.
- C. A hardware issue caused a unidirectional link; BFD detected the issue at Layer 2 and prevented a broadcast storm.
- D. BFD was set up incorrectly on Switch-2, so it caused Switch-2 to lose adjacency with Switch-1 rather than repair the session.

Correct Answer: D